

## External Electronic Controller Type S-EP 6

The multifunctional external controller S-EP 6 serves to control a central lubrication system (progressive or multi-line) time- or pulse-dependent. In factory different operating modes can be adjusted:

- A) Control by time
- B) Control by strokes
- C) Control by revolutions

Furthermore, additional functions can be selected:

- D) Evaluation of the grease level monitoring
- E) Evaluation of the micro switch of the pressure relief valve

Operating mode and additional functions have to be selected at the order. They cannot be adjusted later!

The controller S-EP 6 has to be installed at a dry place, e.g. in the driver's cab.

Controller S-EP 6

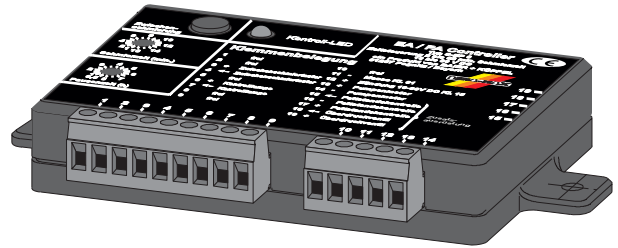

### A) Control by time

Operating principle:

After ignition has been switched on, the yellow LED at the housing of the controller respectively the illuminated push-button in the driver's cab (optional) burns for 1.5 seconds. This indicates the operational readiness.

If the controller is connected for the first time, a lubrication cycle starts.

At the end of the lubrication time, break time starts and the pump is switched off. The following lubrication cycles occur depending on the selected lubrication times and break times.

If the ignition is interrupted during a lubrication cycle, the process stops. It will continue at the same position, if the ignition is switched on again.

The push-button "extra lubrication" releases at any time an additional lubrication, if the ignition is switched on. Running cycles will be reset, and the process starts new.

The extra lubrication also serves to check the function of the controller.

Function diagram:

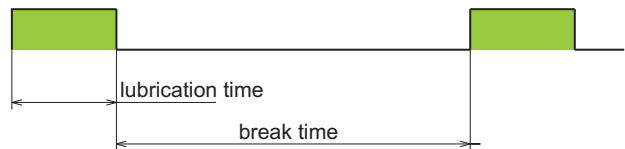

Indication of the yellow LED:  
Ready for operation

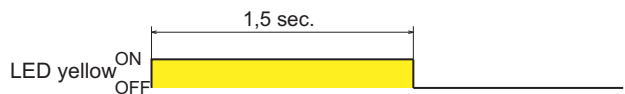

Dimensions:

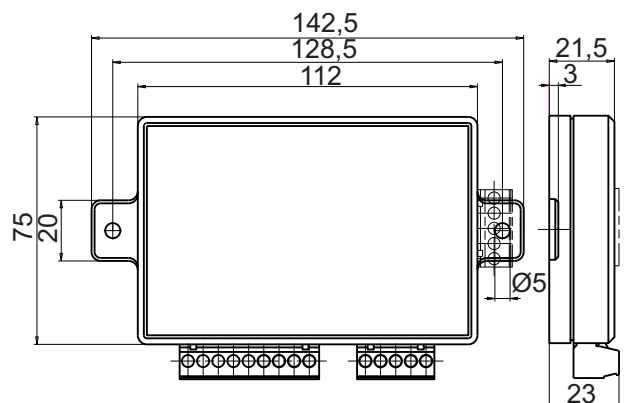

## External Electronic Controller Type S-EP 6

The lubrication times/break times can be adjusted at the controller with a screwdriver.

**The lubrication time can be adjusted in two ranges:**

Range I: 1 - 16 min

Range II: 2 - 32 min

**Adjustment of the break time:**

Break time: 0,5 - 8 h

The yellow LED indicates the function of the controller.

The signal of the yellow LED can also be indicated with a signal lamp or an illuminated push-button (optional) in the driver's cab.

### Technical data:

Power supply:	10 - 30 V DC
Current (at 24 V):	25 mA
Max. current load:	6 A
Output signal lamp (low active):	max. 1 A
Temperature range: storage	-40°C - +85°C
in operation	-30°C - +70°C
Weight:	approx. 160 g
Clamp cross section:	0,34 - 2,5 mm <sup>2</sup>
Installation position:	any
Protective system:	IP 41

**Before the electrical connection:  
Observe the voltage of the pump motor.**

Range I  
(16 notches/each 1 min)

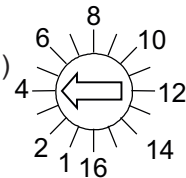

Range II  
(16 notches/each 2 min)

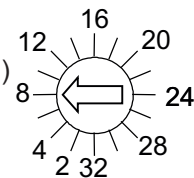

Break time:  
(16 notches/each 0,5 h)

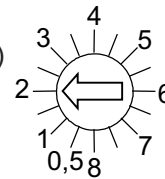

Indication of the yellow LED:  
Lubrication cycle runs



Connection:

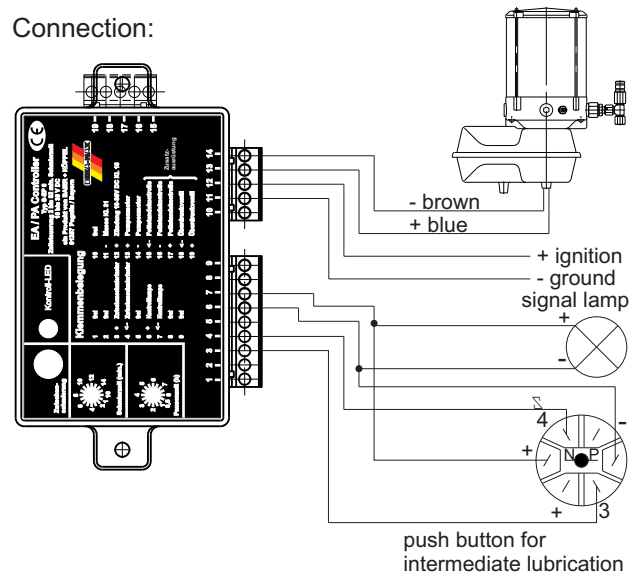

## External Electronic Controller Type S-EP 6

### B) Control by strokes

The S-EP 6 controller is also suitable for the monitoring of a progressive distributor. Therefore a proximity switch or a micro switch is installed at the progressive distributor.

The pistons of the progressive distributor are moved by the conveyed lubricant and trigger the proximity switch, which sends a signal to the controller.

If this signal does not come for more than 4,2 min (monitoring time) during a lubrication cycle, the controller indicates a fault and switches the pump off.

After the malfunction has been repaired, the fault can be reset with the push button for intermediate lubrication.

The signal of the yellow LED can also be indicated with a signal lamp or an illuminated push-button (optional) in the driver's cab.

If the ignition is interrupted during a lubrication cycle, the process stops. It will continue at the same position, if the ignition is switched on again.

The number of strokes and the break time can be adjusted with a screwdriver.

Number of strokes: 1 - 16 strokes

Break time: 0,5 - 8 h

### Example of assembly:

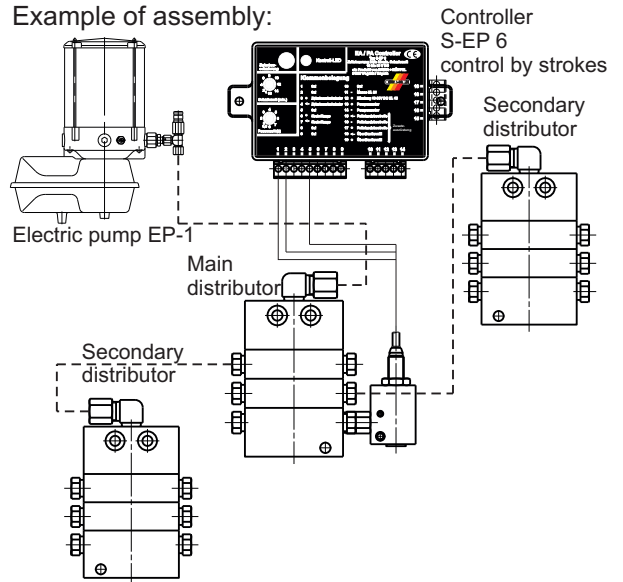

### Indication of the yellow LED:

Lubrication process is working

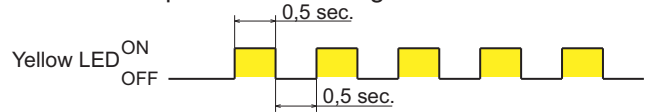

Malfunction: No signal during the monitoring time

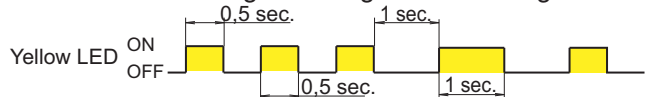

Number of strokes:  
(16 notches/each 1 stroke)

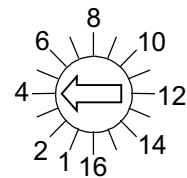

Break time:  
(16 notches/each 0,5 h)

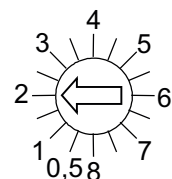

## External Electronic Controller Type S-EP 6

Connection of the proximity switch to the controller:

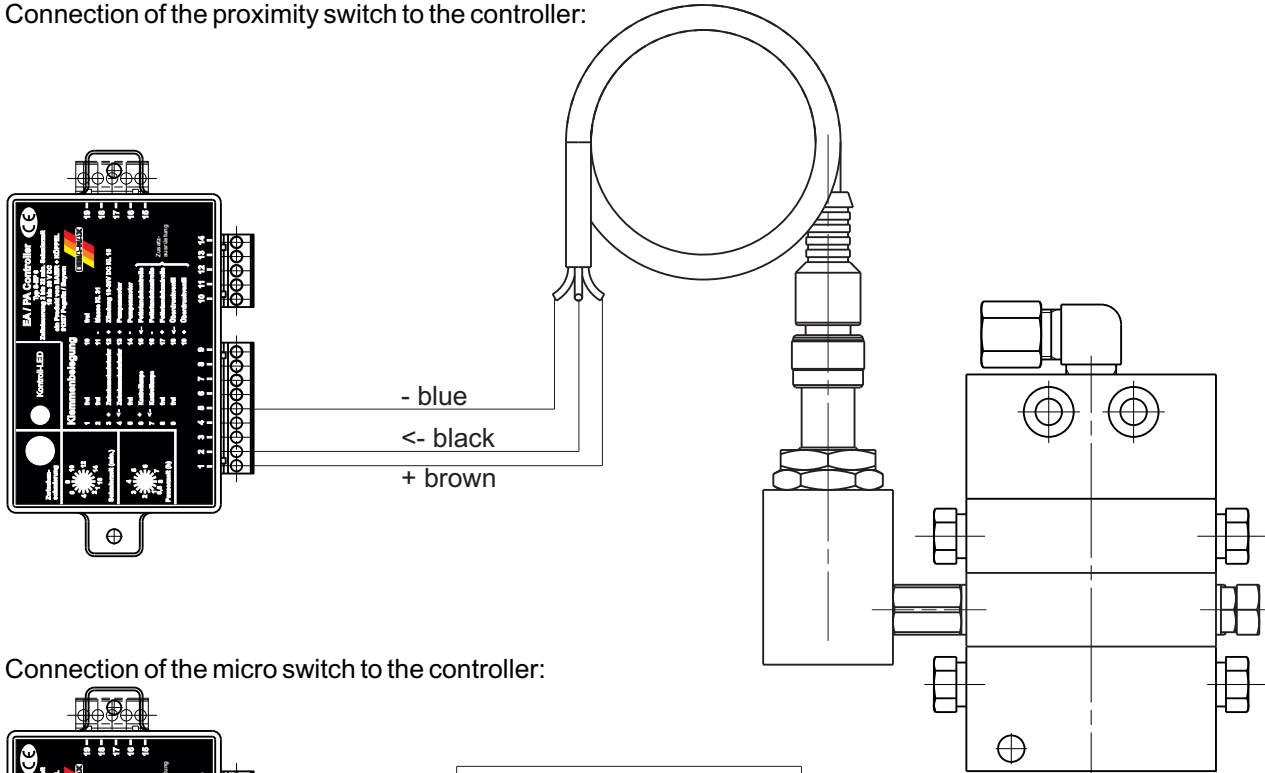

Connection of the micro switch to the controller:

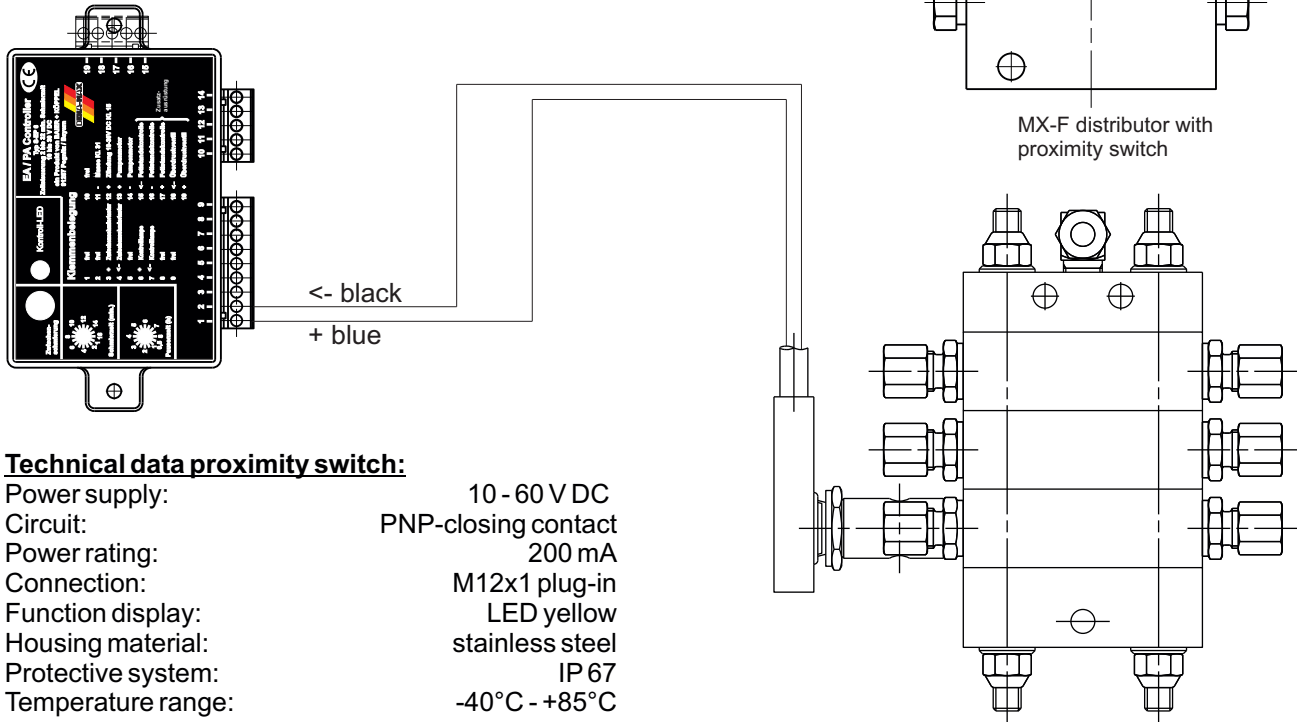

MX-F distributor with proximity switch

### **Technical data proximity switch:**

Power supply:	10 - 60 V DC
Circuit:	PNP-closing contact
Power rating:	200 mA
Connection:	M12x1 plug-in
Function display:	LED yellow
Housing material:	stainless steel
Protective system:	IP 67
Temperature range:	-40°C - +85°C

### **Technical data micro switch:**

Power supply:	up to 250 V
Max. current load:	1 A
Circuit:	alternating switch
Temperature range:	-15°C - +80°C
Protective system:	IP 65

Other connections see page 2.

**Before the electrical connection:  
Observe the voltage of the pump motor.**

## External Electronic Controller Type S-EP 6

### C) Control by revolutions

With low ambient temperatures or high back pressure it might occur, that the rotational speed of the pump is lower than normal. If the rotational speed of the pump is lower than 15 rpm, the delivery rate is lower, too.

For this case it is possible to monitor the revolutions of the pump. The pump will be connected over a sliding contact with the controller and with each revolution a signal comes.

If this signal does not come 30s after starting the cycle or between two revolutions, the controller indicates a fault and stops the pump. The yellow LED starts to flash.

The signal of the yellow LED can also be indicated with a signal lamp or an illuminated push-button (optional) in the driver's cab.

The fault can be reset with the push-button for the intermediate lubrication.

The number of revolutions of the pump can be adjusted with a screwdriver.

Number of pump revolutions:

10 - 160 revolutions

Break time:

0,5 - 8 h

Indication of the yellow LED:

Lubrication process is working (no signal)



Malfunction:

No signal during monitoring time:



Number of pump revolutions:

(16 notches/each 10 revolutions)

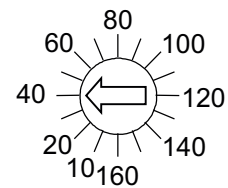

Break time

(16 notches/each 0,5 h)

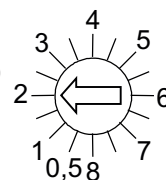

## External Electronic Controller Type S-EP 6

### D) Evaluation of the grease level monitoring:

Grease pumps can be equipped with a electrical grease level monitoring. To this purpose a capacitive proximity switch is installed in the container.

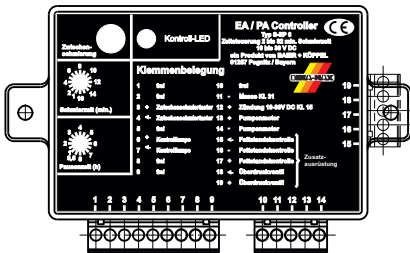

As long as there is enough grease in the container, the grease level control sends a signal to the controller.

If this signal does not come for more than 10 seconds, the controller switches the pump off and indicates a fault. The yellow LED starts to flash.

After the container has been filled again, the controller deletes the fault automatically and continues the lubrication cycle at the same position.

The signal of the yellow LED can also be indicated with a signal lamp or an illuminated push-button (optional) in the driver's cab.

The grease level monitoring can be evaluated in all modes of operation.

Grease level monitoring installed in a 2.5 kg container:

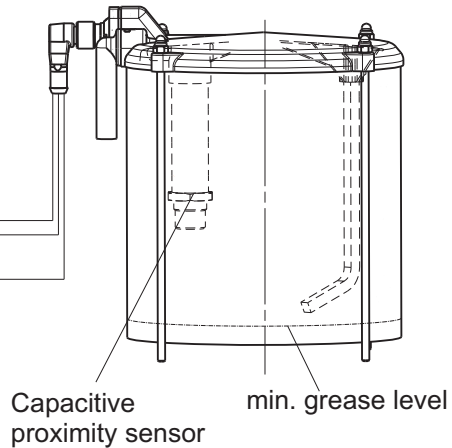

Indication of the yellow LED:  
Grease level too low

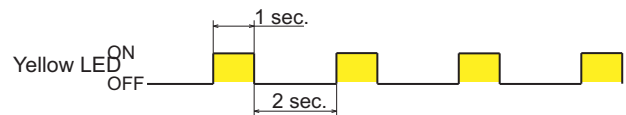

### Technical data:

Power supply:	10 - 60 V DC
Circuit:	PNP closing contact
Protective system:	IP 67
Ambient temperature:	-25°C - +70°C
Connection:	Solid connector
Terminal:	no 1 = 10 - 60 V DC
	no 2 = ground
	no 3 = opening
	⊥ = free

**Before the electrical connection:  
Observe the voltage of the pump motor.**



## External Electronic Controller Type S-EP 6

### E) Evaluation of the micro switch of the pressure relief valve

The S-EP 6 controller can also be used to monitor the max. operating pressure of the lubrication system. Therefore a micro switch is installed at the pump element.

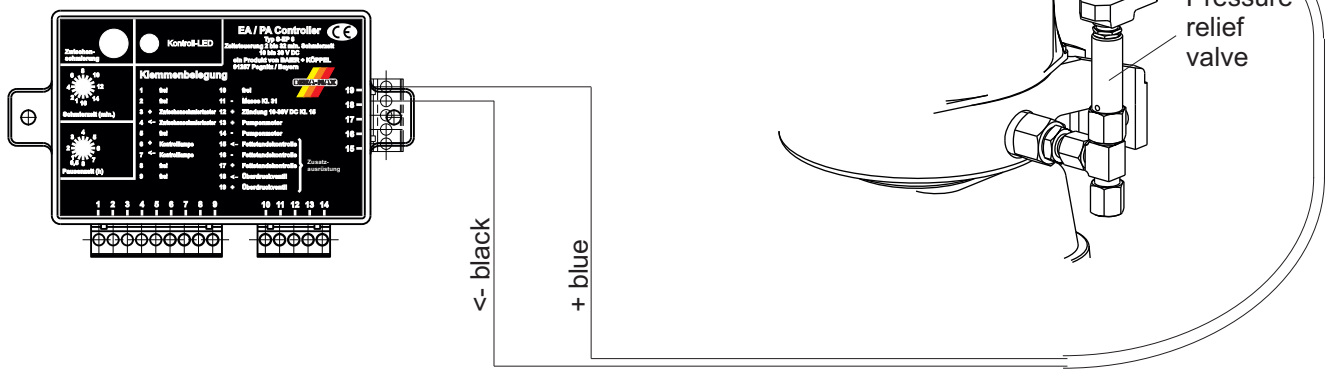

If a malfunction in the system occurs (for example the blocking of a lubrication point), a pressure of more than 250 bar is generated. The micro switch appeals and sends a signal to the controller. The controller switches the pump off and the yellow LED starts flashing.

After the malfunction has been repaired, the fault can be reset with the push button for the intermediate lubrication and the pump starts working again.

The signal of the yellow LED can also be indicated with a signal lamp or an illuminated push-button (optional) in the driver's cab.

The microswitch can be evaluated in  
- all three modes of operation  
- all three lubrication cycles.

Indication of the yellow LED:  
Overpressure in the lubrication system

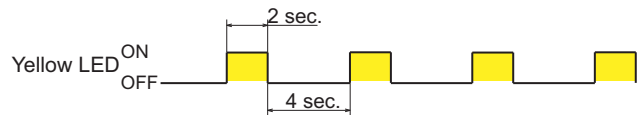

#### **Technical data:**

Power supply:	10 - 60 V DC
Max. current:	1,7 A
Circuit:	alternating switch
Temperature range:	-25°C - +85°C
Protective system:	IP 67

**Before the electrical connection:**  
**Observe the voltage of the pump motor.**



# External Electronic Controller Type S-EP 6

Terminal diagram - all connections

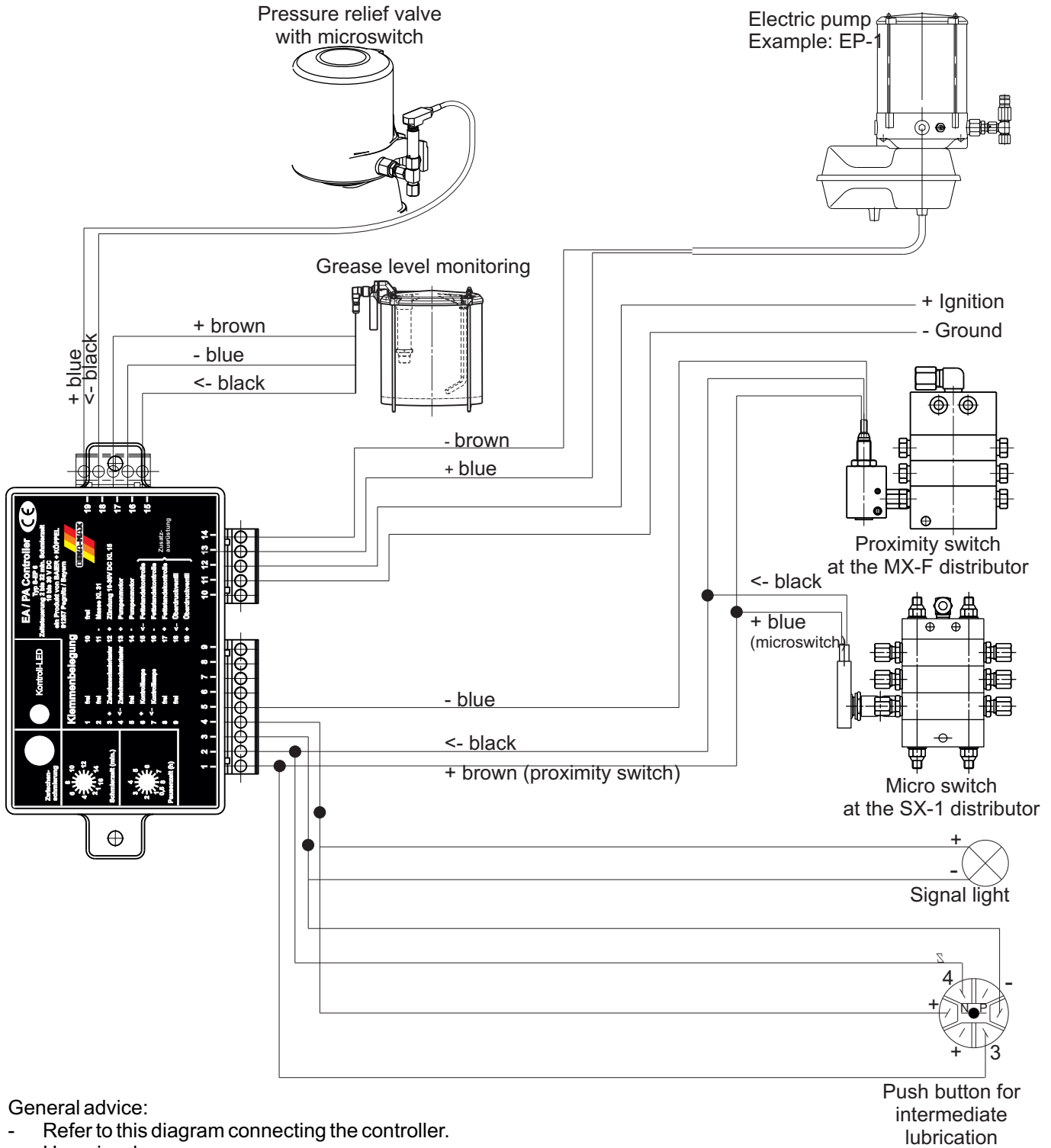

**General advice:**

- Refer to this diagram connecting the controller.
- Use wire sleeves.

**The guarantee of the controller ends**

- if it has been connected in a wrong way (verifiable!)
- in the case of unauthorized opening of the housing.



## External Electronic Controller Type S-EP 6

### Summary of indications

The yellow LED indicates the functions of the pump.  
 The signal of the yellow LED can also be indicated with a signal lamp or an illuminated push-button (optional) in the driver's cab.

- 1) Ready for operation  
 (after ignition has been switched on)

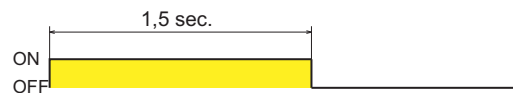

- 2) Lubrication process is working (no fault)  
 Advice: No signal in the operating mode  
 "control by revolutions"!

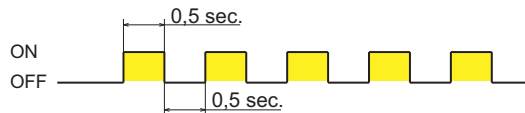

- 3) Cycle fault  
 (no piston stroke at the progressive distributor =  
 no signal during monitoring time)

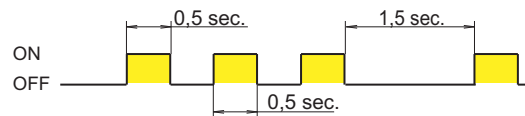

- 4) Revolution fault  
 (no revolutions of the pump=  
 no signal during monitoring time)

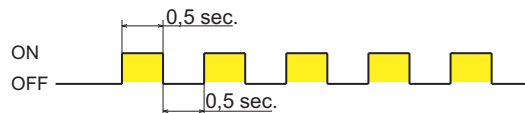

- 5) Grease level too low

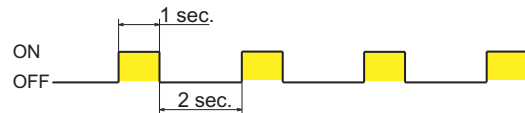

- 6) Overpressure in the system

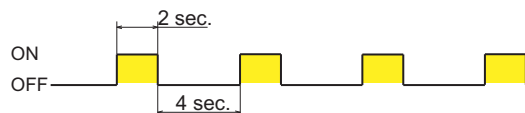

## External Electronic Controller Type S-EP 6

Order example:

Type-no.	2166 . 9000 . 1 . 1 . 00		
Operating mode:			
Control by time	Lubrication time range		
	1 - 16 min	1	
	2 - 32 min	2	
Control by strokes			3
Control by revolutions			4
Additional functions			
Yes			1
No			0
Special design	00		

